

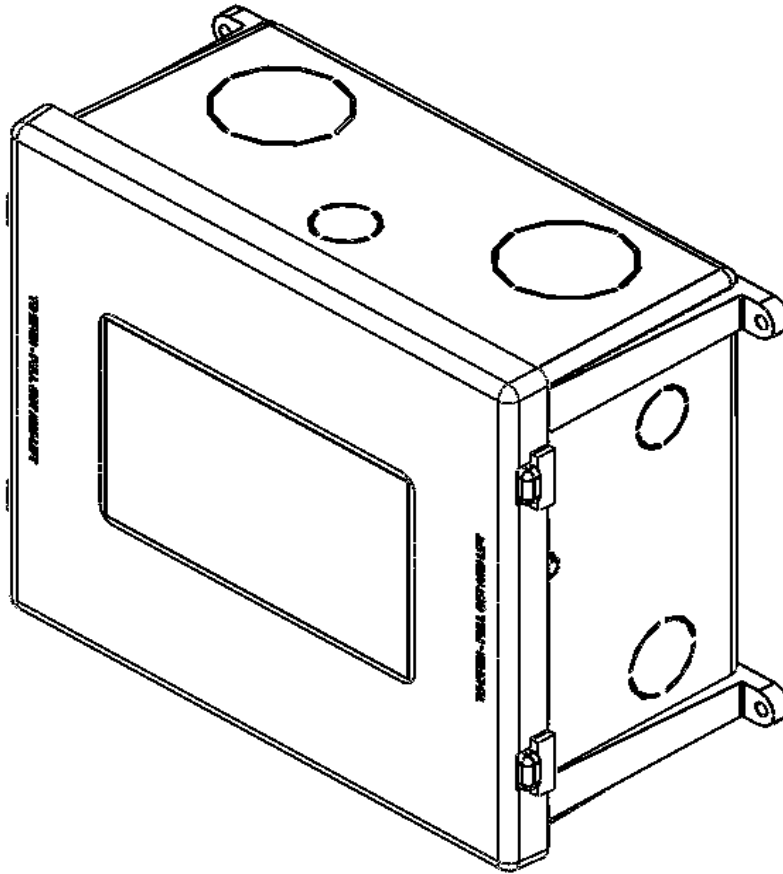

Installation and Operation Guide for PD5100 Automatic Transfer Switch



Member



Progressive Dynamics, Inc.

507 Industrial Rd
Marshall, MI 49068
www.progressivedyn.com

Table of Contents

Installation Instructions	1
Troubleshooting	2 - 3

LIMITED WARRANTY

- I. **LIMITED WARRANTY:** Progressive Dynamics, Inc. warrants its automatic transfer switch to be free from defects in material or workmanship under normal use and service; and limits the remedies to repair or replacement.
- II. **DURATION:** This warranty shall extend for a period of one year from the original date of purchase, and is valid only within the continental limits of the United States and Canada.
- III. **WARRANTY EXCLUSIONS:** This warranty specifically does not apply to:
 - A. Any product which has been repaired or altered in any way by an unauthorized person or service station;
 - B. Damage caused by excessive input voltage, misuse, negligence or accident; or an external force;
 - C. Any product which has been connected, installed or adjusted or used other than in accordance with the instructions furnished, or has had the serial number altered, defaced or removed;
 - D. Cost of all services performed in removing and re-installing the product; and
 - E. ANY LOST PROFITS, LOST SAVINGS, LOSS OF USE OF ENJOYMENT OR OTHER INCIDENTAL DAMAGES ARISING OUT OF THE USE OF, OR INABILITY TO USE, THE PRODUCT. THIS INCLUDES DAMAGES TO PROPERTY AND, TO THE EXTENT PERMITTED BY LAW, DAMAGES FOR PERSONAL INJURY. THIS WARRANTY IS IN LIEU OF ALL OTHER WARRANTIES, INCLUDING IMPLIED WARRANTIES OF MERCHANTABILITY AND FITNESS FOR A PARTICULAR PURPOSE.
- IV. **PROOF OF PURCHASE:** A warranty claim must be accompanied by proof of the date of purchase.
- V. **CLAIM PROCEDURE:** Upon discovery of any defect, Progressive Dynamics, Inc. shall be supplied the following information:
 - A. Name and address of the claimant;
 - B. Model and serial number of the product;
 - C. Name, year and model of the vehicle in which the product was installed;
 - D. Copy of original bill of sale showing date of purchase;
 - E. Complete description of the claimed defect.

Upon determination that a warranty claim exists (a defect in material or workmanship occurring under normal use and service,) the product shall be shipped postage prepaid to Progressive Dynamics, Inc. together with proof of purchase. The product will be repaired or replaced and returned postage prepaid.

Progressive Dynamics, Inc.
507 Industrial Road
Marshall, MI 49068
service@progressivedyn.com
www.progressivedyn.com

For Warranty Service Call: (269) 781-4242



WARNING: TORQUE ALL CONNECTIONS PER LABEL – EXCESSIVE TORQUE MAY CAUSE DAMAGE TO CONNECTIONS LEADING TO A FIRE CAUSING PROPERTY DAMAGE, SERIOUS INJURY OR DEATH.

WARNING: SHOCK HAZARD - DUE TO THE HIGH VOLTAGES ASSOCIATED WITH ITS OPERATION ONLY QUALIFIED SERVICE PERSONNEL SHOULD INSTALL OR TROUBLESHOOT THIS TRANSFER SWITCH! ALL APPLICABLE CODES AND STANDARDS MUST BE MET WHEN INSTALLING THIS DEVICE. SEE WIRING DIAGRAM INSIDE OF THE COVER AND ON THE BACK OF THIS PAGE. IMPROPER HANDLING OR INSTALLATION MAY CAUSE SERIOUS INJURY OR DEATH.

WARNING: THE 5100 AUTOMATIC TRANSFER SWITCHES ARE NOT IGNITION PROTECTED AND SHOULD NOT BE MOUNTED IN THE SAME COMPARTMENT AS THE BATTERIES OR FLAMMABLE MATERIALS SUCH AS GASOLINE. DO NOT MOUNT THE TRANSFER SWITCH IN THE GENERATOR OR LP GAS COMPARTMENT. A FIRE CAUSING PROPERTY DAMAGE SERIOUS INJURY OR DEATH COULD RESULT!

Installation Instructions

The 5100 Automatic Transfer Switches are not suitable for outdoor locations and should be mounted on a flat surface with 4 screws (not included) in a protected area. We recommend that the transfer switch be mounted as close to the shore power and generator power cords as practical to reduce voltage loss.

Description of Operation

- When the shore power is applied the relay is at rest and power is transferred to the panel.
- When Generator power is applied there is a 20-45 second delay and then the relay activates transferring Generator power to the panel.
- If shore power returns while the Gen power is present nothing will happen. When the Gen power is removed the relay will drop out and allow the shore side to supply power.
- Generator overrides shore power.

Specifications (Specifications subject to change without notice)		
Model	PD5110010	PD5110610
Electrical rating	120 VAC 60Hz @ 30A	120 VAC 60Hz @ 30A
Dimensions	9.65”L x 7.28”W x 4.75”H	9.65”L x 7.28”W x 4.75”H
Weight	3 lbs	3 lbs

Consult a licensed electrician or an RV technician for installation assistance

The Automatic Transfer Switch (ATS) is designed to be quickly tested for proper operation and repair if necessary. All critical circuits are located on the easily replaceable circuit board. The following will describe how to test for proper circuit board operation and how to replace it if necessary.

1. Disconnect all AC power from the RV and make sure the generator is “OFF”
2. Remove the cover from the ATS by sliding a screwdriver blade under the edge of the cover and pry off.
3. Start the generator and wait 20-45 seconds to see if the relay will energize. If the relay does not energize, go to Step #4. If the relay energizes, but the Generator still does not provide 120 VAC power to the RV, use an AC Voltmeter to check for 120 VAC power from the Generator to the ATS. Then check for 120 VAC at the N.O. (Normally Open) terminals of the relay. If 120 VAC power is present at the N.O. terminals of the relay, you have a wiring problem between the ATS and the RV AC Distribution panel. If no voltage is measured on the N.O. terminals, the entire unit will need to be replaced.
4. With the Generator running use an insulated screwdriver to carefully push down on the center arm of the relay, until the center arm of the relay makes contact with the N.O. contacts of the relay. If AC power is now present in the RV the circuit board in the ATS has failed and must be replaced.



Use the blade of a screwdriver to pry off the cover of the ATS

Relay Contacts Burned and Pitted

If the Relay Contacts are burned and pitted (see photo below), the Generator has a problem and it's voltage is dropping below 90 VAC under load. If this problem occurs, you must repair or replace the Generator and the complete ATS.



REPLACING THE ATS CIRCUIT BOARD

WARNING: Disconnect all AC power from the RV and turn the generator “OFF”.

1. Before replacing circuit board: With the power off check for 3-7k ohms on the red and yellow wires to the relay. If the coil checks open or shorted, replace the entire unit.

- Pull the circuit board out of the plastic housing and then using a screwdriver blade, pry the Yellow, White, Black and Red wires off the connectors on the circuit board.

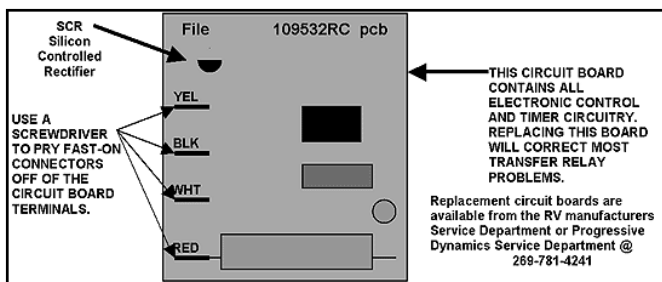

- Replace the Circuit Board and reconnect the four (4) wires and test the system by starting the Generator. The Relay should energize in 20-45 seconds. If the relay does not energize, the relay coil is probably open and the ATS must be replaced.

WIRING DIAGRAM:

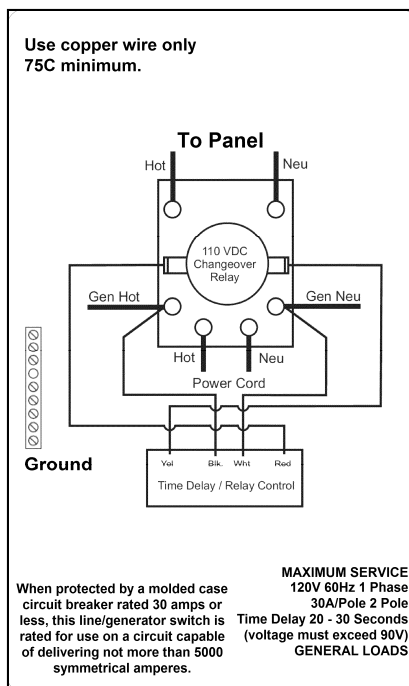

30A@120V

PD51 Time-Out Disable



The PD51 control board is not field modifiable. To disable the time-out function, install a jumper wire in the area marked J1 on the PCB. This modification will require removing the circuit board and soldering a jumper wire in the J1 location.

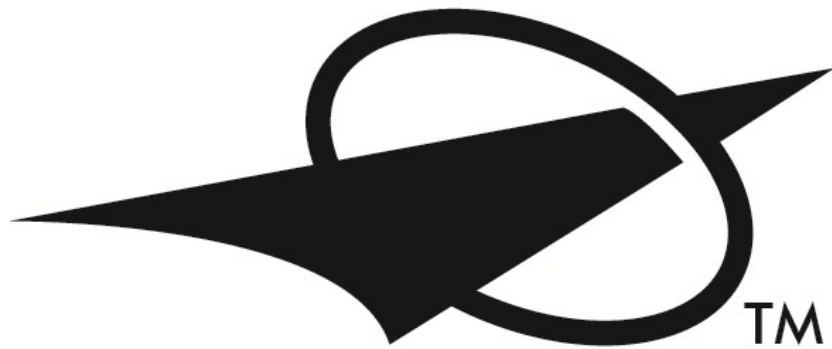

Progressive Dynamics, Inc.

507 Industrial Rd
Marshall, MI 49068

Visit us on the web for other great products.

www.progressivedyn.com